

... MORE MACHINES

# SLAUGHTERING

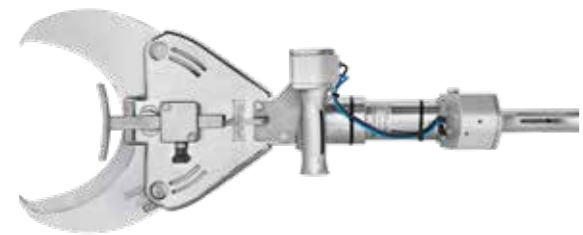

► NS21 - Neck Shear



► SVSS - Steam-Vacuum-Sanitizer-Systems

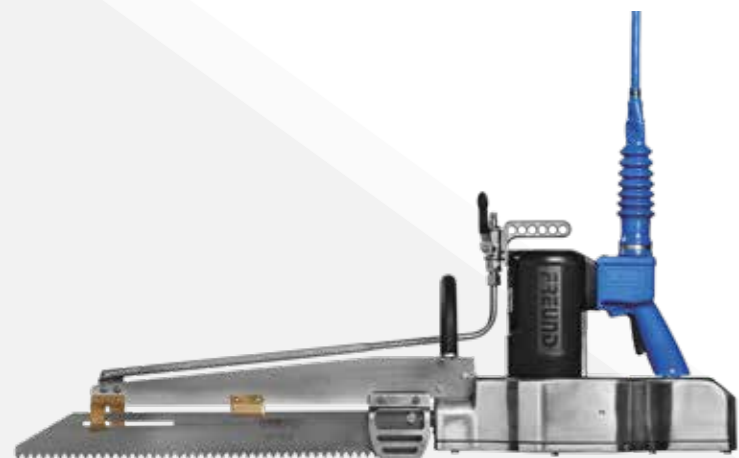

► SH60-03 - Reciprocating Splitting Saw



FREUND Maschinenfabrik GmbH & Co. KG  
 Schulze-Delitzsch-Str. 38      Fon: +49 5251 1659-0  
 33100 Paderborn, GERMANY      Fax: +49 5251 1659-75  
 mail@freund.eu      www.freund-germany.com

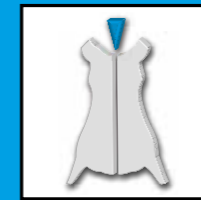

SLAUGHTERING

# SPLITTER-BAND-SAW



S10\_hjs\_j\_TB



TRADITION  
+ INNOVATION  
FUTURE

www.freund-germany.com



# SLAUGHTERING

## WBS51-08



■ also available in 42V / 115V versions from spring 2025



Splitter-band-saw for halving pigs (industrial operation) and for spread-frame slaughtering, but also suitable for mixed operations with sows and cattle slaughtering

- suitable for low spreader bar slaughtering
- line slaughtering (high-frequency) in industrial operations
- our convenient, reliable belt tensioning system always ensures optimum belt tension and thus supports a long belt service life
- new generation of motors



# SLAUGHTERING

## FEATURES

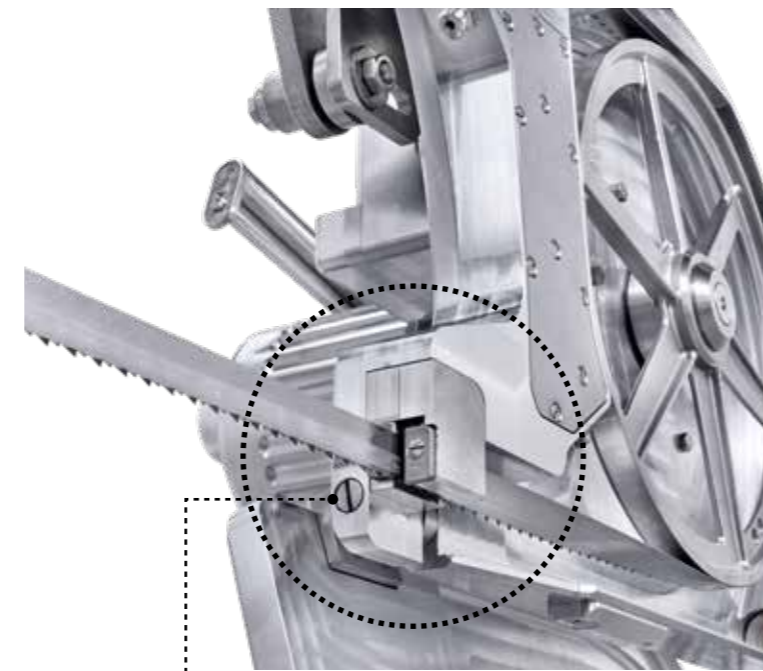

▶ Improved belt guide

### EQUIPMENT - SPLITTER-BAND-SAW

- 400V supply voltage (via SG WDS-51 switchgear)
- saw blade change with tension limitation (torque limit)
- one-hand operation of the cover
- two-hand safety circuit
- ergonomically designed control lever
- integrated internal disinfection
- configurable equipment
- easy to maintain, few wearing parts
- hourly output: 400 pigs

- effectively arranged flushing nozzles reduce the bonedust residues on the carcass and, if necessary, save the downstream process step 'cleaning of bonedust'
- improved ergonomics of the splitter-band-saw ensure fatigue-reduced working and create greater employee acceptance
- maintenance-friendly design reduces maintenance times and the resulting costs
- hygienic design for quick and thorough cleaning after daily use
- quick belt change thanks to ONE-HAND lid lock
- maintenance-friendly assembly
- suitable for right- and left-handed users
- sturdy Design



- Flushing nozzle
- manual band tension

# SLAUGHTERING

## FEATURES

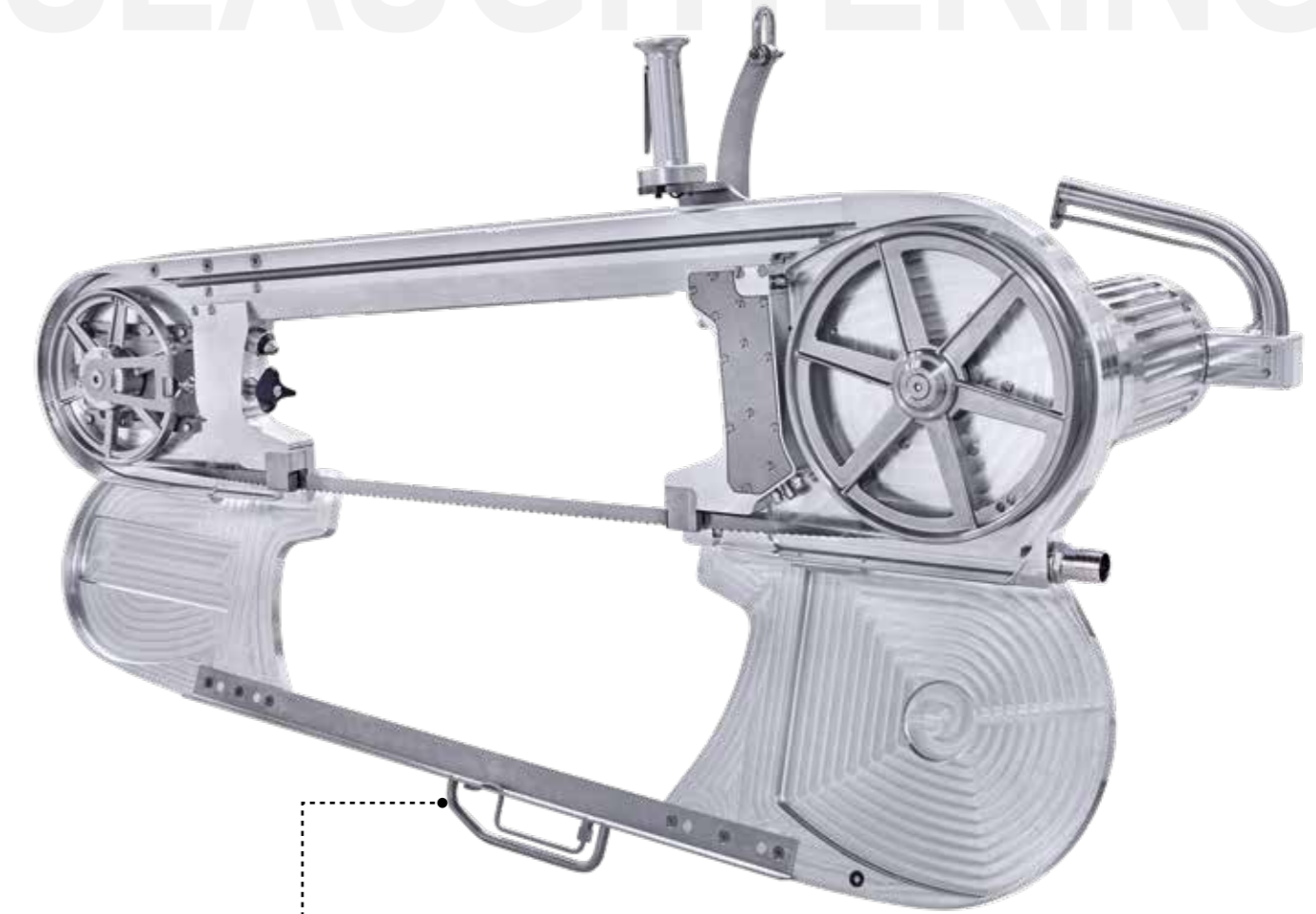

quick belt change thanks to ONE-HAND lid lock

### TECHNICAL DATA

WEIGHT	[kg] / [lbs]	68 / 150
LENGTH	[mm] / [inch]	1491 / 59
CUTTING DEPTH	[mm] / [inch]	199-246 / 8-10
CUTTING WIDTH	[mm] / [inch]	516 / 20
DRIVE TYPE		electric, 3-phase (Three-phase)
MOTOR POWER	[W] / [HP]	2.300 / 3.0
CURRENT FREQUENCY	[Hz]	50
PROTECTION CLASS	[Motor]	IP 67



PART	WBS51-08
SWITCHGEAR SG WDS-51	180-001-032
Individual parts from assemblies can be requested via FA under the serial number	
OPTIONAL ACCESSORIES	
SPRING BALANCER F70-3	920-476-000
DISINFECTION CABIN DESK-04	913-505-002
LUBRICANT 1kg, Dose	171-500-010